

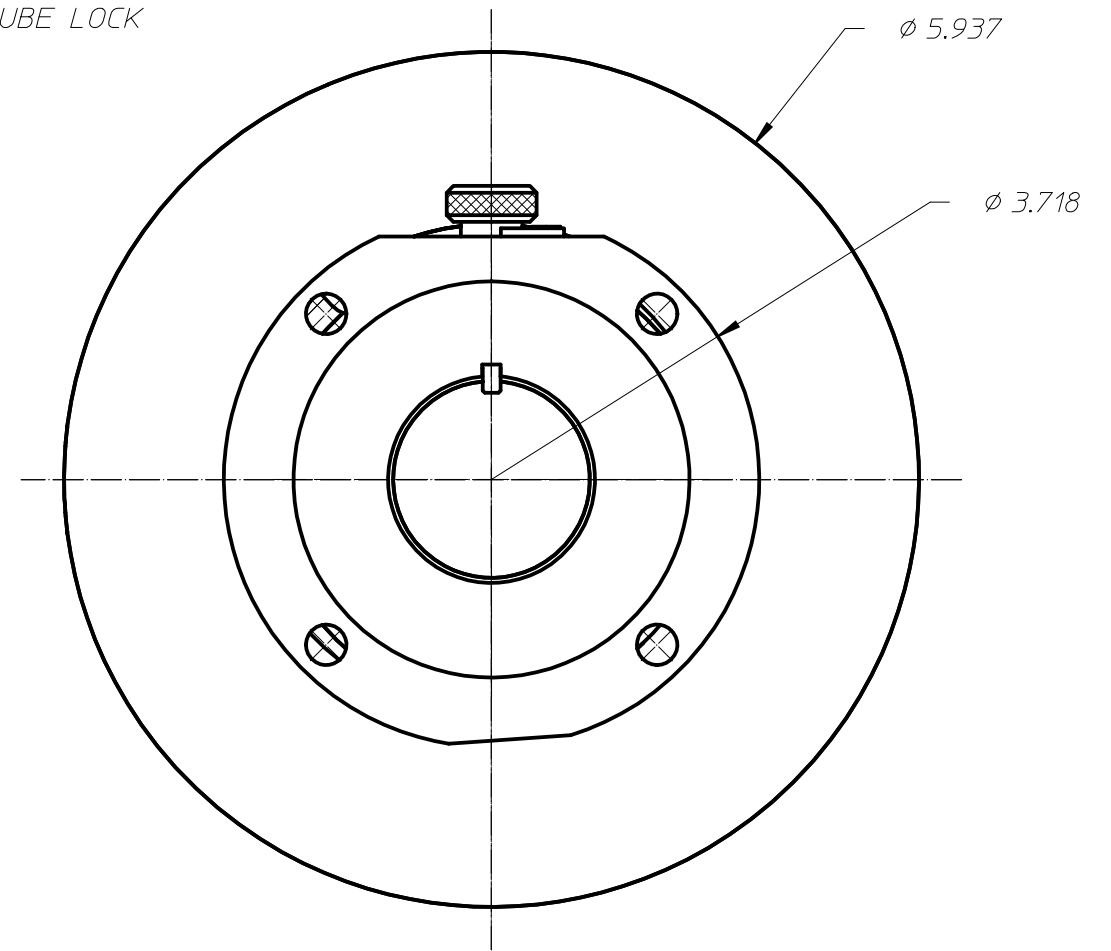

DRAWTUBE LOCK



MATERIAL		 THE DUNHAM TOOL COMPANY DIVISION OF LISLE CORPORATION	
FINISH	HEAT TREAT		
REFERENCE DRAWING:		TITLE	
UNLESS OTHERWISE SPECIFIED DECIMAL DIM. .xx ±.015 .xxx ±.005 FRACTIONAL DIM. ±1/64 ANGLES ±1° ROUND EDGES .005-.015 CORNERS FILLETS .005-.020 SURFACE FINISH 32/√		DACC COLLET CLOSER	
USED ON	FM-09-047	DR.	DATE
	2/19/2015	CHK.	DATE
SCALE	PART NO.	DACC	