

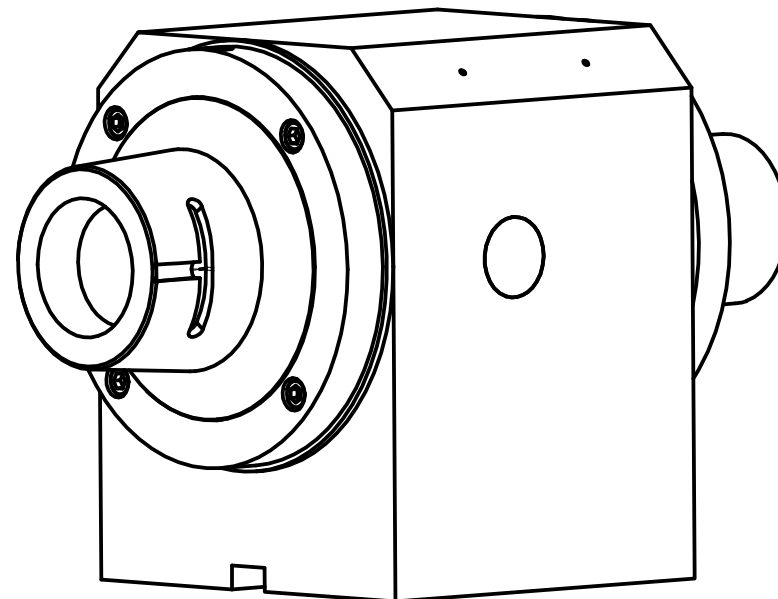

(OPTIONAL) AIR PURGE  
5-7 P.S.I. 2/16/98

MOMENT OF INERTIA: .0364 WK2 SQUARED  
RUN TORQUE: .09 FT-LBS  
START TORQUE: .05 FT-LBS

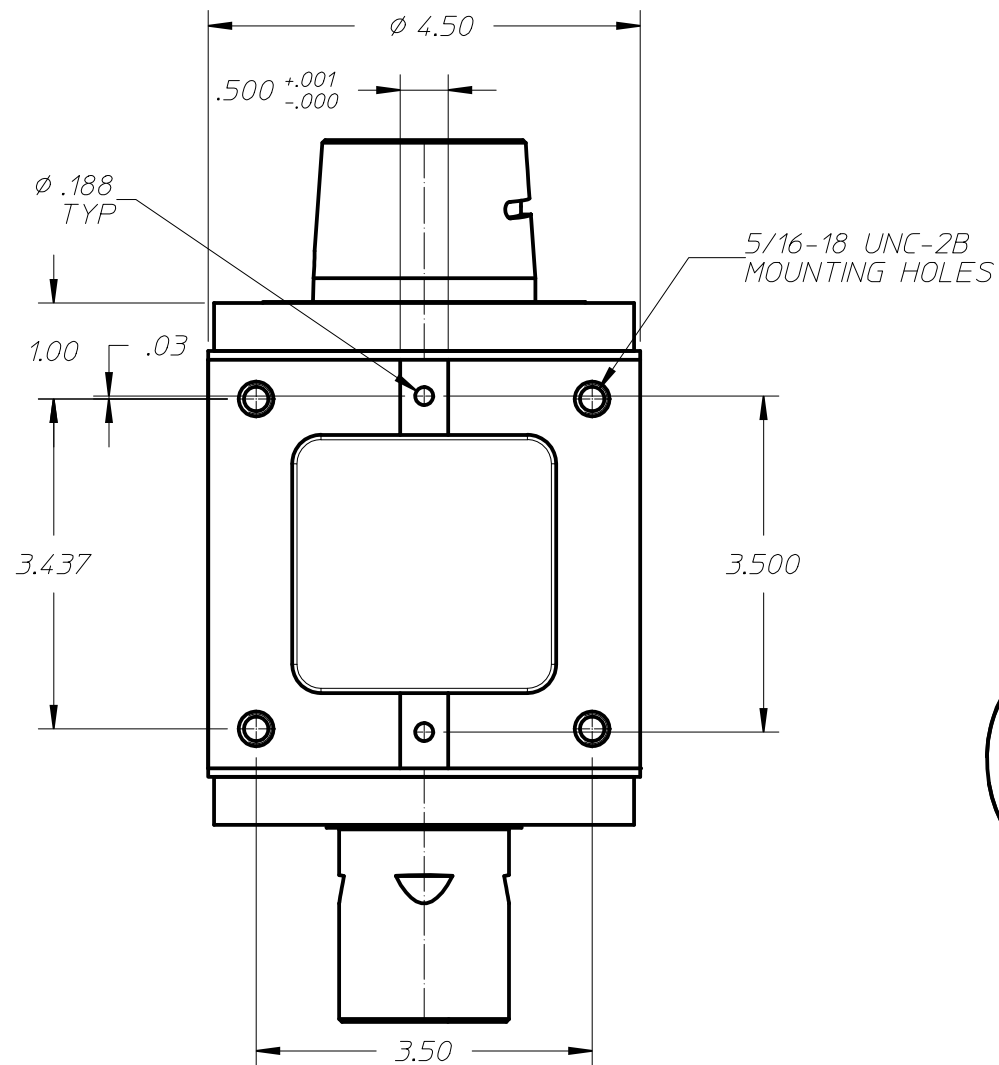

MATERIAL		 <b>DUNHAM</b> TOOL COMPANY DIVISION OF LISLE CORPORATION	
FINISH	HEAT TREAT		
REFERENCE DRAWING: MB185-B		TITLE	
UNLESS OTHERWISE SPECIFIED DECIMAL DIM. .xx ±.015 .xxx ±.005 FRACTIONAL DIM. ±1/64 ANGLES ±1° ROUND EDGES .005-.015 CORNERS FILLETS .005-.020 SURFACE FINISH 32/√		CUSTOMER TAPER NOSE CENTRIC PRINT	
 USED ON SCALE	FM-09-047 2/19/2015	DR. MM CHK. DATE	DATE AUG-12-19
	PART NO. D020-50MT-2		